

PFA116

Mount Adapter



Features

- Material: Aluminum
- Mount Adapter
- Neat & Integrated design

Technical Specifications

Model	PFA116	PFA116-N
General		
Material	Aluminum	Aluminum
Dimension (W x H x D)	Φ60mm*58mm(Φ2.36"x2.28")	Φ60mm*58mm(Φ2.36"x2.28")
Weight	0.2kg(0.44lb)	0.2kg(0.44lb)
Load Bearing	8.0kg(17.64lb)	8.0kg(17.64lb)
Pipe Thread	G1.5	NPT1.5
Color	White	White
Operating Temperature	-40°C ~60°C(-40°F ~140°F)	-40°C ~60°C(-40°F ~140°F)
Humidity	<90% RH	<90% RH
Applicable Model	Please see "Accessory Selection"	

Order Information

Type	Part Number	Description
Camera mount	PFA116	Mount adapter _Neutral, no brand
	PFA116-N	Mount adapter _Neutral, no brand

Dimensions (mm/inch)

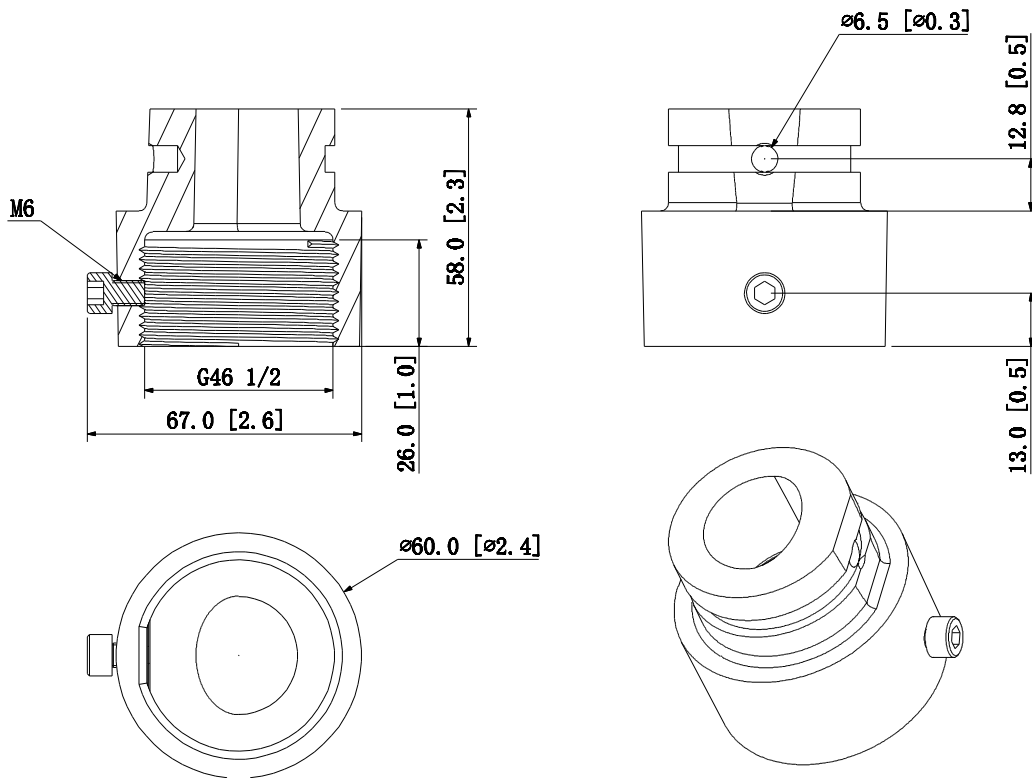

Application

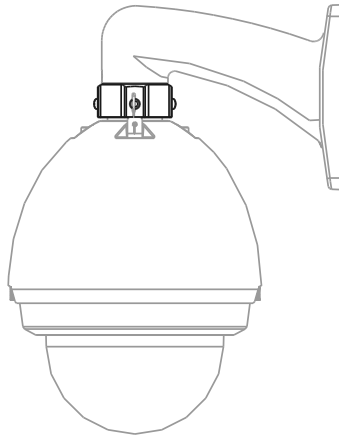

Package Information

- Mount adapter *1

Package data	
Box Dimension	65mmx65mmx65mm (2.56"x2.56"x2.56")
Box Weight	0.2kg (0.44lb)
Protective Box Dimension	360mmx220mmx315mm (14.17"x8.66"x12.4")
Box In Protective Box	60 In 1