

# DH-PFM364L-D1

Integrated Solar Power System (without Lithium Battery)



- Integrated die casting casing
- Aluminum alloy frame
- Monocrystalline silicon solar panel
- Remote monitoring with app
- Maximum Power Point Tracking (MPPT) charging controller
- RS-485 communication
- Electronic protection



## Series Overview

This integrated solar power system consists of solar panels, Maximum Power Point Tracking (MPPT) charging controller, and mounting brackets. It provides stable power supply for devices such as IP cameras with high conversion charging controller. Compared with conventional solar power systems, it is compact, portable, and easy to install, disassemble and maintain.

## Functions

### Integrated die casting casing

Compact structure integrated with solar panel and charging controller to improve the appearance, installation, and maintenance of the system.

### Monocrystalline silicon solar panel

Adopt efficient monocrystalline silicon solar panel to greatly improve light absorbance efficiency and power generation performance with dusky light.

### Remote monitoring with app

With Dahua cameras, you can remotely monitor the system operation status and receive alarm notifications for low battery in real time.

### Maximum Power Point Tracking (MPPT) charging controller

MPPT controller helps significantly improve the energy utilization efficiency of the system, and raise the charging efficiency by 10%–30% compared with conventional PWM controller.

## RS-485 communication

RS-485 port and standard Modbus protocol can satisfy communication requirements in various scenarios.

## Electronic protection

Comprehensive electronic protection: Current limiting, short circuit, and reverse current protection of the solar panel; reverse connection, overvoltage, over-discharge, and over-temperature protection of the lithium battery; overload and short circuit protection.

## Scene

### General application

Suitable to be installed in places such as scenic spots, courtyards, roads, farms, communities, and small construction sites.

### Small business application

Applicable to scenarios where power is difficult to obtain, such as mining areas, oil/power transmission lines, forest fire prevention, and water conservancy.

### Special application

Temporary monitoring of mobile toilets, mobile garbage stations, outdoor small-scale competitions, and more.

### Technical Specification

#### Solar Panel

Type	Monocrystalline silicon
Max. Power	60W
Solar Cell Efficiency	21%
Max. Mechanical Load	5400Pa

#### Protection

Over-discharge Protection Voltage	11.1V DC
Low Temperature Charging	≤-10°C (14°F)
Low Temperature Discharging	≤-20°C (-4°F)
Grade	IP66
Others	Over temperature, overvoltage of the battery, overload, and short circuit

#### Port

Power Output	Φ5.5 mm × Φ2.1 mm × 12 mm (Φ0.22" × Φ0.08" × 0.47")
RS-485	1

#### General

Main Body Material	Die casting aluminum
Installation	Pole mount, installed on 76 mm to 96 mm (Φ3.0"-Φ3.78") poles
Adjustable Angle	Horizontal: 0°-360° Vertical: -75°-80°
Product Dimensions	1149.5 mm × 367.6 mm × 430.2 mm (45.26" × 14.47" × 16.94")
Packaging Dimensions	1353 mm × 548 mm × 364 mm (53.27" × 21.57" × 14.33")
Packaging Method	1 pc in each carton
Net Weight	16 kg (35.27 lb)
Gross Weight	22.5 kg (49.60 lb)

#### Environment

Operating Altitude	<3000 m (9842.5 ft)
Applicable Area	Areas with daily solar radiation >4.5 h
Operating Temperature	-20°C to 60°C (-4°F to 140°F)
Operating Humidity	<95% (RH)
Storage Temperature	0°C to 40°C (32°F to 104°F)
Storage Humidity	<95% (RH)

#### Certification

Certifications	CE: EN61000-6-2, EN61000-6-4 FCC: FCC Part 15 Subpart B
----------------	--

### Ordering Information

Type	Model	Description
Solar Power Series	DH-PFM363L-D1	Integrated Solar Power System (without Lithium Battery)
Accessories	/	Camera Mounting Plate
	PFM372-L45-4S14P	Integrated Solar Lithium Battery

### Accessories

#### Included



Camera Mounting Plate

#### Optional



PFM372-L45-4S14P  
Integrated Solar Lithium Battery

### Package Information

Camera Mounting Plate	1
S3.0L Wrench	1
S4.0L Wrench	1
S6.0L Wrench	1
S10.0L Wrench	1
M8*20 Screws	2
M4*12 Screws	5

Dimensions (mm/inch)

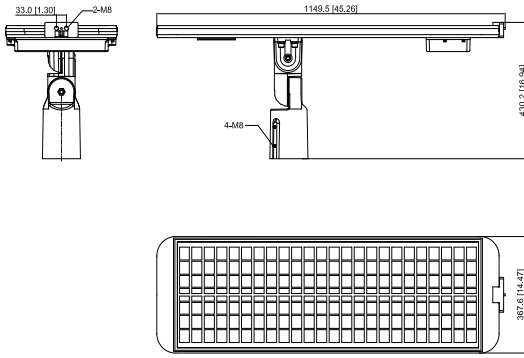

Application

