

# PFM372-L45-4S14P

Integrated Solar Lithium Battery



- Die casting aluminum material, IP66 protection grade
- Simple structure, compact and light
- Applicable to the integrated solar system DH-PFM364L-D1, DH-PFM363L-D1, and DH-PFM363L-SD1

### Function

Charging Current	9A
Discharge Current	9A
Rated Voltage	DC12.8V
Internal Resistance	≤80mΩ
Nominal Capacity	45Ah
Charging Voltage	Max.DC14.6V
Max.Current	Charging: 10A, Discharging: 10A

### Certification

Certification	CE: EN 61000-6-3, EN IEC 61000-6-1 FCC: FCC Part 15, Subpart B
---------------	---

### Ordering Information

Type	Model	Description
Solar Power Series	PFM372-L45-4S14P	Integrated Solar Lithium Bttery

### Package Information

S5.0L Wrench	1
M6*30 Screws	6

### Dimensions (mm/inch)

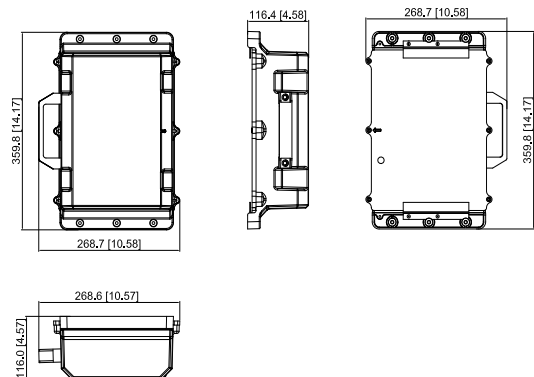

### Technical Specification

#### Protection

Grade	IP66
-------	------

#### Connection

Connection	M15 female connector
------------	----------------------

#### Application

Applicable Device	DH-PFM364L-D1, DH-PFM363L-D1, and DH-PFM363L-SD1
-------------------	--

#### General

Product Dimensions	Outer: 359.8 mm × 268.7mm × 116.0 mm(14.17" × 10.58" × 4.57") Inner: 282.0 mm × 209.0 mm × 98.5 mm (11.10" × 8.23" × 3.88")
--------------------	--

Material	Die casting aluminum
----------	----------------------

Color	Grey
-------	------

Net Weight	8.5 kg (18.74 lb)
------------	-------------------

Gross Weight	9.8 kg (21.61 lb)
--------------	-------------------

Packaging Dimensions	459 mm × 349 mm × 209 mm (18.07" × 13.74" × 8.23")
----------------------	--

Packaging Method	1 pc in each carton
------------------	---------------------

#### Environment

Operating Temperature	-20°C to 60°C (-4°F to 140°F)
-----------------------	-------------------------------

Operating Humidity	<95% (RH)
--------------------	-----------

Storage Temperature	0°C to 40°C (32°F to 104°F)
---------------------	-----------------------------

Storage Humidity	<95% (RH)
------------------	-----------